



IBC INTERGLOBE BUSINESS CONCERN

Innovative and Sustainable Industrial Solutions Under One Roof



 40, Strand Road, Model House,
4th Floor, Room No.-17A, Kolkata-
700001. Office no.: 033-2242 9046

 98300 81231 / 93301 81231

 interglobe.business@gmail.com

 www.interglobebusiness.in

INNOVATIVE & SUSTAINABILITY

We are a passionate team driven to tackle real-world challenges by delivering innovative and reliable industrial solutions.

TABLE OF CONTENTS

• About Our Company	001
• Vision	002
• Our Success	002
• Creativity	002
• Our Clientele	003 - 004
• SWOT Analysis	005
• 4P's Marketing	006
• Interglobe 2.0	
- Product Overview	008 - 010
• Interglobe Heritage	
- Product Overview	011 - 022
• Our Solutions	023 - 024
• Collaborations- IT service	025
• Market Targeting	026 - 027
• Our Team	028
• Our Contact	029
• Thank You Page	030

ABOUT OUR COMPANY



A BRIEF STORY ABOUT THE COMPANY

In 1985, **Interglobe Business Concern** was born, led by the visionary Mr. Debesh Bharati. We began by supplying ITC Ltd. Munger, Bihar and soon expanded across West Bengal and Uttarakhand committed to delivering exceptional quality and service across India. Our dedication attracted multinational giants like Hindustan Unilever, PepsiCo, Berger, L&T among others. For over three decades, we've thrived, driven by our unwavering motto: "**Quality is our motto and service is our commitment.**" As we continue our journey, we invite you to join us in pursuing excellence and embracing a future full of possibilities. Thank you for being a part of our story.

Shreeji Enterprises, a sister company, specializes in the bulk supply of plywood, boards, and associated materials, ensuring reliable quality and service.

EXCELLENCE IS OUR STANDARD,
AND INTEGRITY IS OUR
CORNERSTONE.



VISION

Customer satisfaction and service are the cornerstones of our business philosophy, enabling us to deliver reliable, customized solutions at competitive prices, ensuring your factory runs smoothly without concerns about breakdowns. Leveraging our extensive experience and cutting-edge **AI solution equipment**, we empower our clients to reach new heights of efficiency and innovation. Our AI-powered systems provide smart, data-driven insights, optimizing performance, predicting maintenance needs, and enhancing precision. This transformative combination of AI and industry expertise helps us turn possibilities into reality, driving continuous improvement and long-term success.

KEY FACTORS

OUR SUCCESS

Interglobe Business Concern boasts a long track record of operational success and has amassed a wealth of valuable knowledge and expertise. Today, we proudly collaborate with renowned companies, consistently delivering exceptional service that exceeds expectations.

CREATIVITY

At our service, we prioritize ingenuity alongside efficiency. In instances of urgency and unavailability of a specific product, we excel in providing innovative substitutes, ensuring uninterrupted workflow and minimizing wait times for our valued clients.

OUR CLIENTELE

Here are a few of our esteemed long-standing clients listed below, yet please note this list is just a glimpse of our extensive clientele.



OUR CLIENTLE

Here are a few of our esteemed long-standing clients listed below, yet please note this list is just a glimpse of our extensive clientele.



& MANY MORE

SWOT ANALYSIS



FUELING PROGRESS BY
ACTUALIZING IDEAS
AND EXEMPLARY
SERVICE.



STRENGTH

- Expertise,
- Collaboration,
- Consistency,
- Competitive edge

WEAKNESSES

- Adaptability
- Waiting period

OPPORTUNITIES

- Expansion,
- Differentiation,
- Technology leverage,
- Partnerships

THREATS

- Competition,
- Economic volatility,
- Technology obsolescence,

4P'S

MARKETING TABLE

PROMOTION

- Online marketing
- Direct marketing
- Advertising
- Strong client relationships
- Proven track record of success

PLACE

- Head office in Kolkata
- Branches in Bihar and Uttarakhand
- Efficient regional service and timely delivery
- Delivering across India & globally

PRODUCT

- Industrial and imported belts
- Standard and Non-Standard Bearing
- Belting and Conveyor Solution (Indigenous and Imported)
- Pneumatic and Hydraulics
- Engineering Spares of Taflon/ Nylon/ Rubber
- General Safety equipments & Tools/ Tackles
- Magnets/ Heater/ Fabricator/ SS pipes/ Fitting/ valves/ Compressor

& Many More

PRICE

- Competitive pricing
- Cost-effective solutions
- High value for investment

PRODUCT OVERVIEW



A BRIEF STORY ABOUT THE PRODUCT

We offer a comprehensive range of high-quality industrial products, including industrial and imported belts, bearings, lubricants, electric and electronic components, heavy and fine chemicals, and precision spare parts made of metallic / non-metallic, rubber, nylon, and Teflon. Our products are tailored to meet the specific needs of various industries, ensuring optimal performance, reliability, and customer satisfaction.

By offering a diverse range of high-quality industrial products and customized solutions, **Interglobe Business Concern** demonstrates its commitment to addressing the needs of the community and the market. Our dedication to innovation, reliability, and customer satisfaction sets us apart as a leader in the industry.

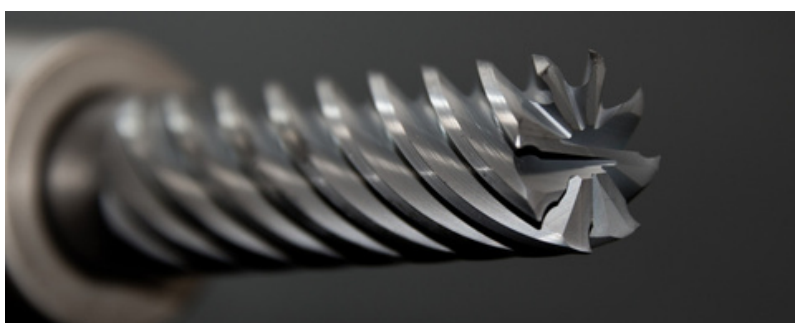

*** THE PRODUCT LIST BELOW IS NOT EXHAUSTIVE, AND WE OFFER CUSTOMIZED SOLUTIONS TAILORED TO MEET YOUR SPECIFIC BUSINESS NEEDS.**

INTERGLOBE BUSINESS CONCERN 2.0

At Interglobe 2.0, we're revolutionizing industries with next-gen technologies! From **collaborative robots and precision laser systems to state-of-the-art welding machines and energy-efficient solar inverters**, our advanced portfolio is designed to supercharge productivity, sustainability, and innovation. We are on a mission to empower businesses with smarter, faster, and greener solutions, ensuring they stay ahead in a rapidly evolving world. Partner with us to shape the future of manufacturing and energy transformation!

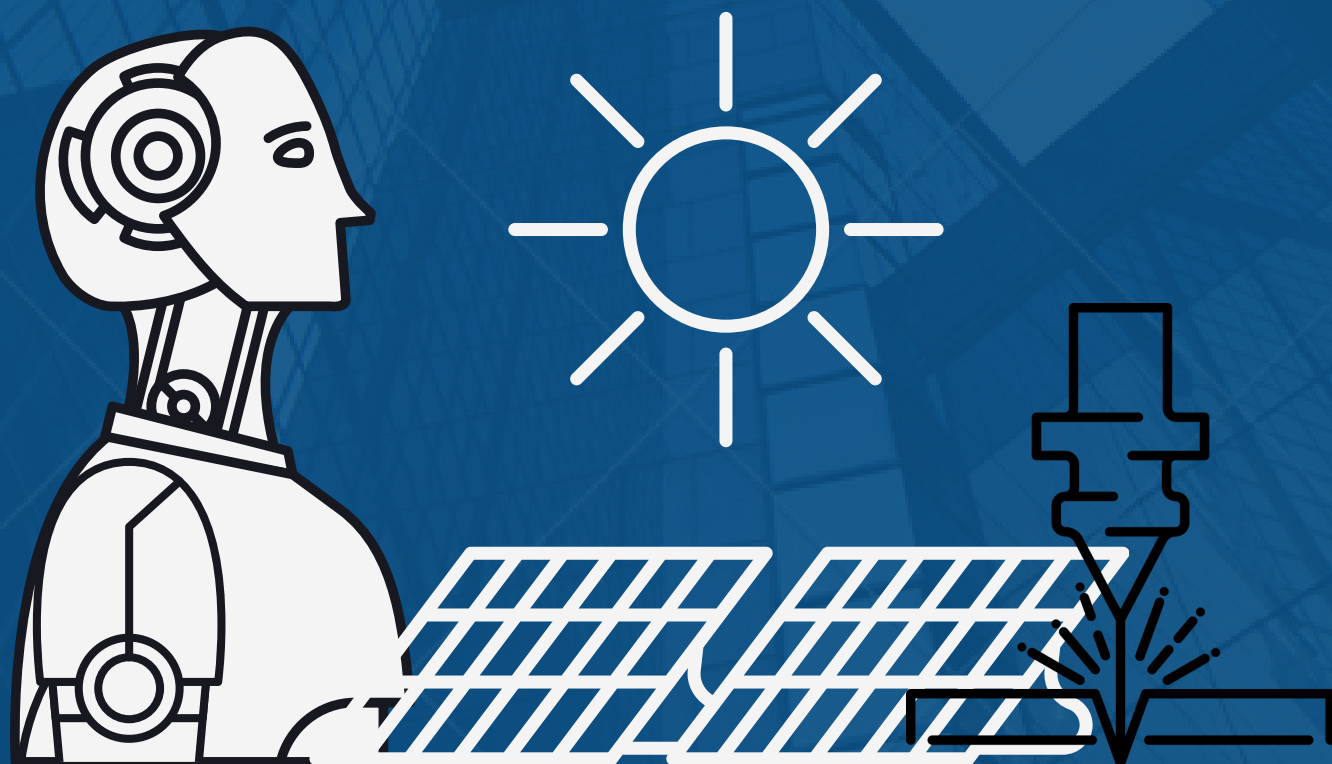

PRODUCT PORTFOLIO



INDUSTRIAL AUTOMATION SOLUTION

- **COLLABORATIVE ROBOTS**



TYPES :

Collaborative Robots

APPLICATION :

It treamline welding, palletizing, assembly, and material handling.

USAGES :

It enable efficient, user-friendly automation without complex programming.

**For additional details, feel free to reach out to us directly.*

- **AI-Driven Multi-Sensor Fire Detection System**

TYPES :

Artificial Intelligence based Advance Fire Detection System for Open Spaces

APPLICATION :

Ideal for open areas like factories, railways, warehouses, and large facilities.

USAGES :

Provides real-time monitoring and rapid fire detection using AI-powered multi-sensor analysis.



PRODUCT PORTFOLIO



LASER MACHINES

• LASER WELDING MACHINE



Laser Welding Machine

TYPES :

It is used in automotive, aerospace, electronics, and manufacturing industries for precise, high-quality welding of metals and alloys.

APPLICATION :

USAGES :

Fast, precise, and clean welding of components with minimal heat distortion and high-strength joints.

• LASER CUTTING MACHINE

TYPES : Laser Cutting Machine

APPLICATION : Used in automotive, aerospace, and metal fabrication for precise cutting of materials like metal, plastic, and wood.

USAGES : Precise cutting, engraving, and etching of materials, providing fast, accurate results with minimal heat impact and material waste.



INTERGLOBE HERITAGE

Pioneering Industrial Excellence for Generations

Interglobe Original is the foundation of industrial excellence, powering industries with trusted, high-quality products and tools for decades. Built on a legacy of reliability, we are committed to keeping your operations seamless and your success unstoppable. With unmatched dedication and exceptional service, we ensure that your business thrives today, tomorrow, and beyond. Partner with us and experience the strength of tradition combined with the drive for excellence!

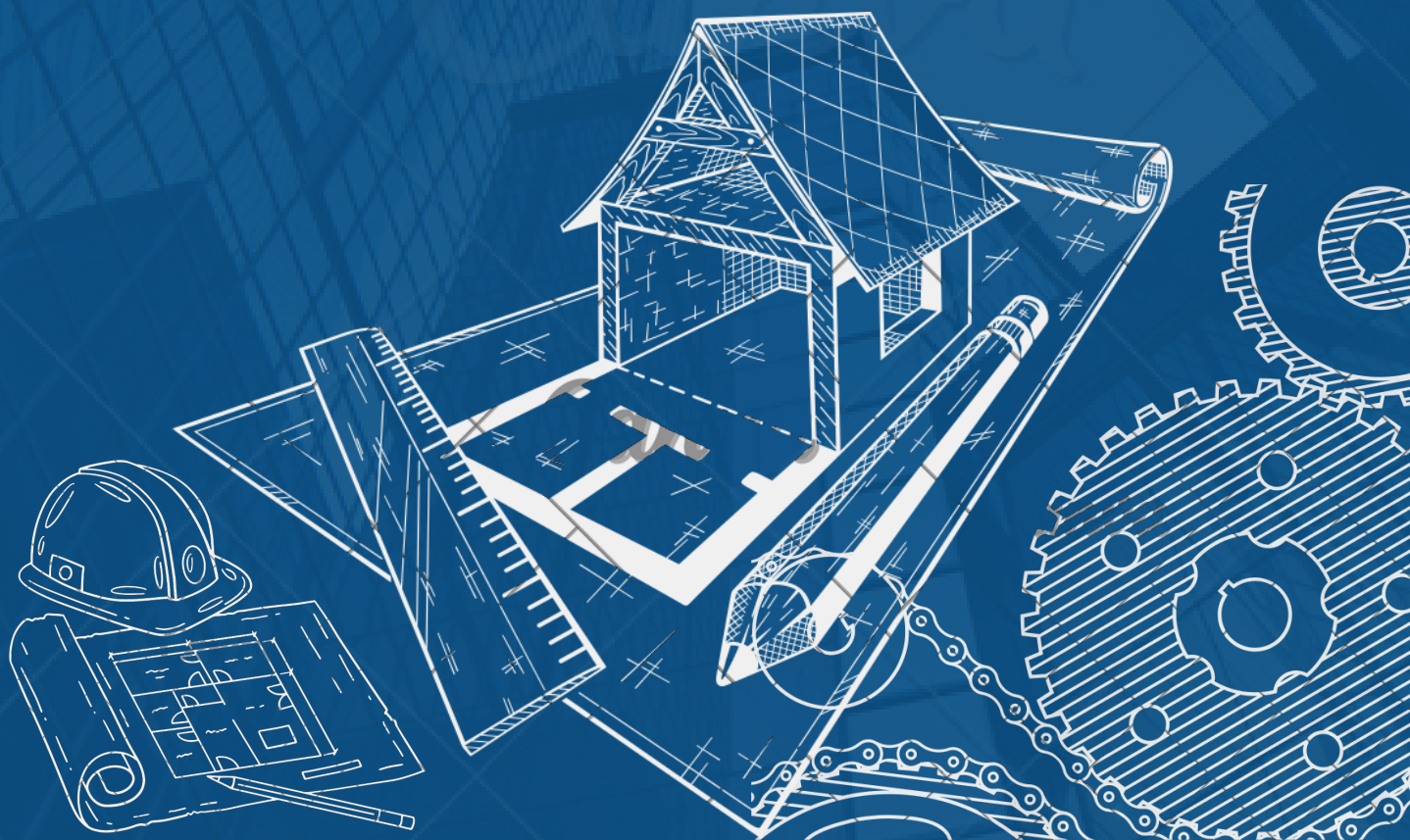

PRODUCT PORTFOLIO



A BRIEF STORY ABOUT THE PORTFOLIO

• EOT CRANES

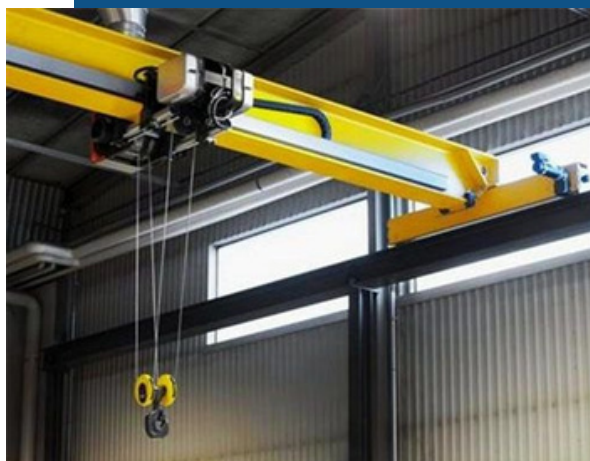

TYPES :

Single Girder EOT Crane.,
Double Girder EOT Crane.,
Under-Slung EOT Crane,
Explosion-Proof EOT Crane.

APPLICATION :

Plants, warehouses, steel plants,
shipyards, railways

USAGES :

Handling and moving heavy
loads, machinery, or materials
across different locations within
the premises.

• FORKLIFT

TYPES :

Counterbalance Forklift, Reach
Truck, Pallet Jack
Manual/Electric), Order Picker
Forklift.

APPLICATION :

Warehouses, logistics hubs,
construction sites, and retail
stores.

USAGES :

Lifting, transporting, and stacking
goods over short distances.



PRODUCT PORTFOLIO



A BRIEF STORY ABOUT THE PORTFOLIO

• SAFETY EQUIPMENTS & ACCESSORIES



TYPES :

Personal Protective Equipment (PPE) (helmets, gloves, goggles), Fall Protection Systems, Respirators and Breathing Apparatus, Emergency Showers and Eyewash Stations.

APPLICATION : Construction sites, factories, fire-prone areas, chemical plants, and laboratories.

USAGES : Enhancing compliance with workplace safety regulations.

• DOZER DUMPER

TYPES : Bulldozer (Crawler/Track and Wheeled), Articulated Dump Trucks, Rigid Haul Dump Trucks.

APPLICATION : Common in mining, construction, and waste management.

USAGES : Moves large quantities of soil, rubble, or waste material efficiently.



PRODUCT PORTFOLIO



A BRIEF STORY ABOUT THE PORTFOLIO

• COMPRESSOR



TYPES :

Reciprocating Compressor, Rotary Screw Compressor, Centrifugal Compressor, Axial Flow Compressor.

APPLICATION :

Widely used in manufacturing industries, workshops, HVAC systems, and power tools.

USAGES :

Provides compressed air for powering pneumatic tools or machinery.

• OIL & GREASES

TYPES :

Engine Oils (synthetic, semi-synthetic, mineral), Gear Oils and Transmission Fluids, Greases (Lithium, Calcium, Synthetic).

APPLICATION : Found in automotive, industrial machinery, and agricultural equipment.

USAGES :

Reduces friction, enhances performance, and extends the life of machinery.

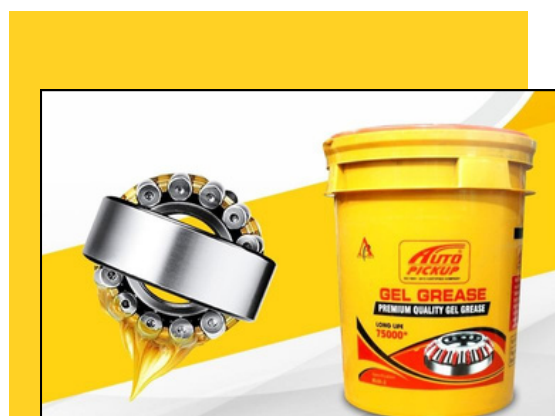

PRODUCT PORTFOLIO



A BRIEF STORY ABOUT THE PORTFOLIO

- **PANEL BOX**



TYPES :

Main Distribution Panel Box, Sub-Distribution Panel Box, Power Control Center (PCC), Motor Control Center (MCC).

APPLICATION : Residential, commercial, and industrial setups to house electrical circuits.

USAGES : Centralizes power distribution while ensuring safety and control.

- **INDUSTRIAL HEATING ELEMENT**

TYPES : Electric Heaters (immersion, cartridge, tubular), Gas-Fired Heaters, Infrared Heaters, Steam Heaters.

APPLICATION : Industries, warehouses, and HVAC systems.

USAGES : Provides heating for processes, equipment, or workspace temperature control.



PRODUCT PORTFOLIO



A BRIEF STORY ABOUT THE PORTFOLIO

• TOOLS

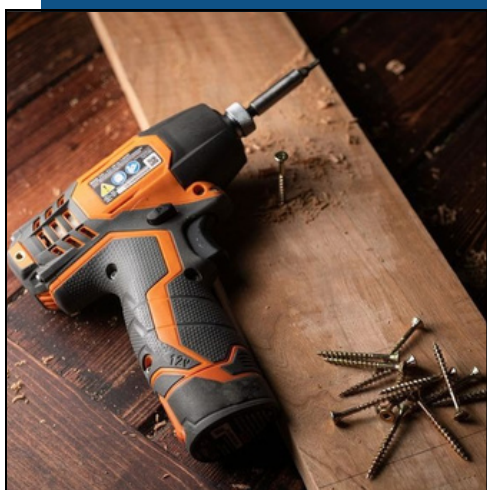

TYPES :

Non- Sparking Tools/ Hand Tools ,
Power Tools , Measuring Tools,
Precision Tools & Tackel

APPLICATION :

Construction, manufacturing,
maintenance, inspection

USAGES :

Perform various tasks such as
fastening, cutting, drilling,
measuring

• LIFTING AND RIGGING EQUIPMENT

TYPES :

Chains, Wire Ropes, Chain
Pulley Blocks, Roller Chains, EOT
Cranes, Lifting Materials

APPLICATION :

Construction sites, manufacturing
plants, warehouses, shipping
yards

USAGES :

Lifting and moving heavy loads
safely and efficiently

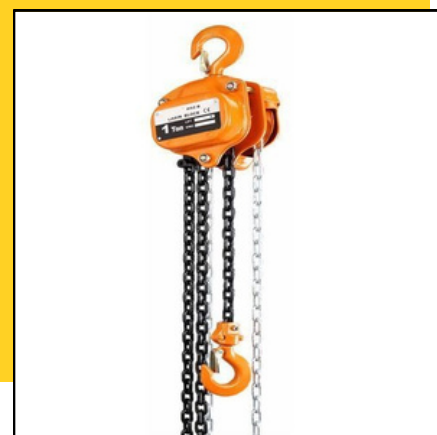

PRODUCT PORTFOLIO



A BRIEF STORY ABOUT THE PORTFOLIO

• STRUCTURAL MATERIALS (MS & SS)



TYPES :

Mild Steel (MS) and Stainless Steel (SS) beams, angles, channels, plates

APPLICATION :

Construction, infrastructure, manufacturing, automotive

USAGES :

Provide structural support, form frameworks and skeletons of buildings, bridges, machinery

• HOSES

TYPES :

High Pressure Hose/ Hydraulic Hose, Suction Hose, Duct Hose, Rubber Hose Pipe & Fittings

APPLICATION :

Industrial, agricultural, commercial, residential

USAGES :

Transfer of liquids, gases, and slurries; ventilation, dust collection



PRODUCT PORTFOLIO



A BRIEF STORY ABOUT THE PORTFOLIO

• RUBBER MATERIALS



TYPES :

Rubber Sheets, Shock Proof Rubber Mats, Oil Seals, Buckets, Materials: Neoprene, Taflon, Silicon, Viton, PU

APPLICATION :

Industrial machinery, electrical insulation, sealing, storage

USAGES :

Insulation, shock absorption, sealing and packing, material storage

• MOTORS AND PUMP

TYPES :

Electric Motors, Hydraulic Pumps, Pneumatic Pumps, Drives

APPLICATION :

Industrial automation, water treatment, agricultural irrigation

USAGES :

Drive mechanical systems, move fluids, provide hydraulic power.



PRODUCT PORTFOLIO



A BRIEF STORY ABOUT THE PORTFOLIO

• BELTS



TYPES :

V Belts, Timing Belts, Conveyor Belts, Nylon Rope Belts, PU Belts, Nylon Leather Sandwich Belts

APPLICATION :

Industrial machinery, automotive, packaging, agriculture

USAGES :

Transmit power, convey materials, synchronize mechanical movements

• FASTENERS

TYPES :

HT Bolts, Nuts, Screws, Washers, Rivets, Anchors

APPLICATION :

Construction, manufacturing, automotive, electronics

USAGES :

Secure materials together, provide structural integrity



PRODUCT PORTFOLIO



A BRIEF STORY ABOUT THE PORTFOLIO

• ELECTRICAL MATERIALS



TYPES :

Switches, Switch Gears, MCB, RCCCB, ELCB, Relays, Sensors, Contactors, Panel Boxes & Spares, Timers

APPLICATION :

Electrical installations, automation systems, power distribution

USAGES :

Control electrical circuits, protect against faults, measure electrical parameters

• MEASURING INSTRUMENTS & TOOLS

TYPES :

Vernier Caliper, Pressure Gauges, Alcohol Tester, Earth Tester/Megger, Vibration Analyser, Moisture Meter, Laser Distance Meter of Miyutoyo & other

APPLICATION :

Quality control, safety inspections, maintenance

USAGES :

Measure dimensions, pressure, alcohol levels, earth resistance, vibrations, moisture content, distances and electric application



PRODUCT PORTFOLIO



A BRIEF STORY ABOUT THE PORTFOLIO

• HYDRAULIC & PNEUMATIC ITEMS

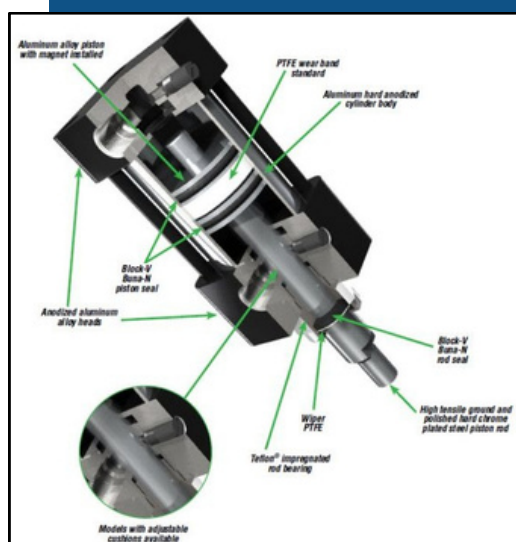

TYPES :

Hydraulic Cylinders, Pneumatic Actuators, Hoses, Fittings, Valves

APPLICATION :

Industrial automation, construction equipment, manufacturing

USAGES :

Provide hydraulic and pneumatic power, control fluid flow

• MAGNETS

TYPES :

Neodymium Magnets, Samarium-Cobalt Magnets, Ceramic Magnets, Alnico Magnets

APPLICATION :

Motors, aerospace, loudspeakers, sensors,

USAGES :

Provide strong magnetic fields for compact applications and Suitable for high-performance and high-temperature environments.

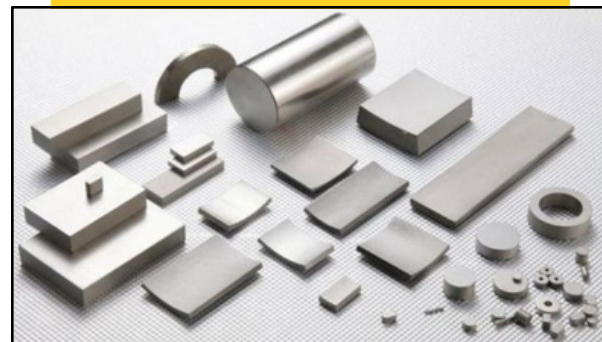

PRODUCT PORTFOLIO



A BRIEF STORY ABOUT THE PORTFOLIO

- FIRE ENGINEERING AND SAFETY EQUIPMENT



TYPES :

Fire Extinguishers (water, foam, CO2, dry chemical), Fire Alarms and Smoke Detectors, Sprinkler Systems, Fire Blankets and Hose Reels.

APPLICATION :

Found in factories, high-rise buildings, oil rigs, and warehouses.

USAGES :

Protects life and property by minimizing fire hazards and enabling quick response.

OUR SOLUTIONS

We collaborate with ventures that solve critical challenges for industry leaders, turning problems into opportunities with innovation and impact.



**RO WATER PLANT
MAINTENANCE**



**IPA TANK
REPAIRING**

OUR SOLUTIONS



EOT CRANE



FLAG MAST

This is just a glimpse of our work—it's not an exhaustive list of what we have accomplished and what we can bring to the table.

COLLABORATIONS



INTERGLOBE BUSINESS CONCERN: IT SERVICES COLLABORATION

We have joined forces with **Skytel Services** to deliver a comprehensive range of IT solutions. This collaboration combines Skytel's expertise in hardware installation, server supply and maintenance, software services, networking, security, and surveillance with our established experience in industrial solutions.

In addition to our partnership with Skytel, we also work with other leading IT service providers to offer cutting-edge technology and customized solutions. Together, we ensure seamless integration of hardware, software, and security services that drive operational efficiency, enhance system reliability, and maintain robust security for our clients.

Our goal is to provide end-to-end IT services that meet the dynamic needs of businesses, supporting them with innovative, scalable, and efficient solutions.



MARKET TARGETING

We are strategically situated in **Kolkata, Haridwar, and Munger**. These locations allow us to efficiently serve key market segments and ensure timely delivery and support across various regions.

By understanding and targeting these key market divisions, Interglobe Business Concern positions itself to effectively serve and expand within these critical sectors. Our comprehensive approach ensures that we meet the diverse needs of our clients, driving growth and success in each targeted market segment.

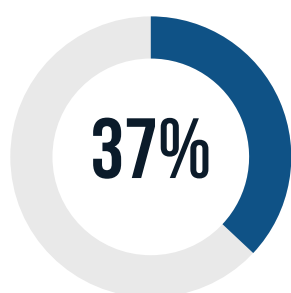

**KOLKATA
(WEST BENGAL)**

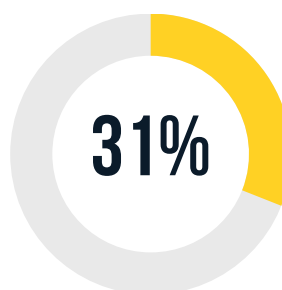

**HARIDWAR
(UTTRAKHAND)**

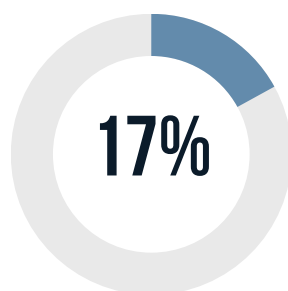

**MUNGER
(BIHAR)**

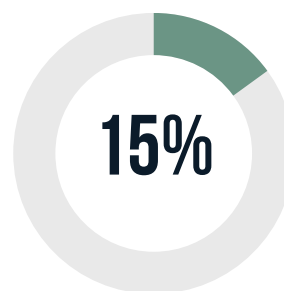

ACROSS INDIA

OUR TEAM IS OUTSTANDING



SHORT STORY ABOUT SUPER TEAM

Our team are the backbone of our success. Many of them have been with us for a significant period, showcasing their loyalty and commitment to the company. Their long-standing association with Interglobe Business Concern highlights their dedication to providing excellent service to our clients.

- ***Naveen Kumar Shaw- Marketing Manager and Regional Manager***

- **Experience:** 25 years with IBC, specializing in industrial machinery and precision parts.
- **Clients:** Led numerous projects for clients like Berger, HUL, EMAMI, L & T

- ***Harishankar Singh- Marketing Executive & Area Manager***

- **Experience:** 24 years working with IBC. Extensive knowledge of procurement and good hold on clients
- **Clients:** Led numerous projects in ITC Haridwar and successfully managed key accounts.

- ***Vishal Saha- Marketing Executive and Area Manager***

- **Experience:** 20 years with IBC, handling clients in Munger and Kolkata.
- **Clients:** Implemented innovative solutions for complex electrical setups in various industries like Berger, HUL, EMAMI.



OUR TEAM IS OUTSTANDING



SHORT STORY ABOUT SUPER TEAM

- **Deepak Gochhayat- Marketing Executive and Regional Manager**

- **Experience:** 16 years with IBC, focusing on electric and electronic components.
- **Clients:** Implemented innovative solutions for complex electrical setups in RAMCO, Keshoram, and Odhisha Mettalicks.

- **Sudama Shaw- Marketing Executive**

- **Experience:** 18 years with IBC, focusing on electric and electronic components.
- **Clients:** Led numerous projects in ITC Haridwar with the support of the team

- **Subhangini Bharati- Office Manager, CFO, Import / Exports**

- **Experience:** 6 years with IBC, focusing on importing and exporting electrical & electronics Items.

- **Supportive Backoffice Team**

Our dedicated backoffice staff is essential to our smooth operations, though we can't list everyone individually. They efficiently handle your accounts, manage logistics, and ensure timely order delivery. Their behind-the-scenes efforts are critical to our seamless and reliable service.

- **Barun Dutta - Senior Accountant (4 years)**
- **Sushma Chowdhury - Junior Accountant (2 years)**
- **Gopal Saha -Delivery Executive (Bihar), 20 years**
- **Amit Gupta - Logistics Coordinator (Pan-India), 6 years**
- **Upen Pal - Delivery Executive (16 years)**

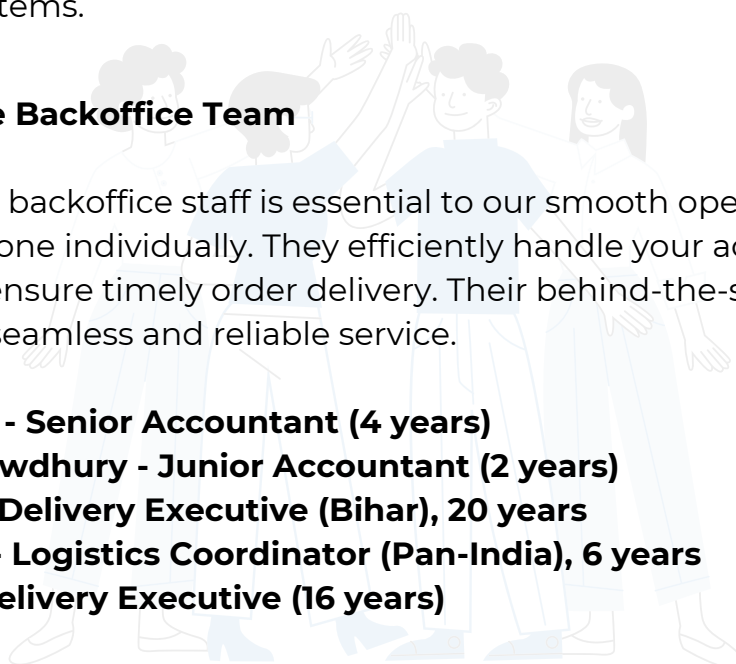

HOW YOU CAN ASK FOR A QUOTATION?

IN THREE WAYS

1. MAIL

interglobe.business@gmail.com

You can mail us your requirement and we will get back to you.

2. WEBSITE

www.interglobebusiness.in/quotation

OR



Simply Scan

3. CALL US

033-2242 9046

Let us know what you require



DON'T STRESS ABOUT MALFUNCTIONS – OUR EXTENSIVE RANGE OF ENGINEERING TOOLS HAS YOU COVERED.

THANK YOU



CONNECT WITH US HERE TO LEARN MORE ABOUT OUR PRODUCTS AND HOW WE CAN SERVE YOUR NEEDS.

ADDRESS

Head Office:

Kolkata: 40 Strand Road, (Room No.17A, 4th Floor & Room No. 34A, 1st Floor), Kolkata-700 001.

Branch Office:

Munger: Bichaligali, Dalhatta Bazar, Munger, Bihar – 811 201.

Haridwar: TARA Apartment, Flat No.3A, Ground Floor, 187/189 Satyam Vihar, Bhupatwala, Haridwar.

TELEPHONE

033-2242 9046

MAIL

interglobe.business@gmail.com

WEBSITE

www.interglobebusiness.in



BRINGING IDEAS & INNOVATION
TO LIFE THROUGH OUR SERVICE